

Communication Input

1/1: GS8599-EX.3

Communication signals input isolated barriers, realize the bi-direction communication between the RS-232 digital signals generated by the field instrument and the RS-485(half duplex) digital signals in the safe area. It also provides isolated power supply for field instruments. The product needs an independent power supply and galvanic isolation among power supply, input and output.

Specification

Supply Voltage: 20~35V DC

Current Consumption:

≤180mA(Supply voltage: 24V, distribution current: 100mA)

≤120mA(Supply voltage: 24V, distribution current: 50mA)

Safe-area:

Signal: RS-485(half duplex)

Transmission delay: ≤10μs

Signal transmission rate: ≤56kbps

Drive ability: up to 32 transceivers

Hazardous-area:

Signal: RS-232

Distribution Power: 5V/100mA、6V/100mA、8V/50mA、9V/50mA、
12V/50mA

Distribution Voltage Deviation: ±10%

Function of the DIP Switches:

Distribution voltage	K1	K2	K3	K4
12V/50mA	OFF	OFF	OFF	OFF
9V/50mA	ON	OFF	OFF	OFF
8V/50mA	ON	ON	OFF	OFF
6V/100mA	ON	ON	ON	OFF
5V/100mA	ON	ON	ON	ON

Power Supply Protection: Power supply reverse protection

EMC: According to IEC 61326-1(GB/T 18268)

Ambient Temperature: -25°C~+60°C

Dielectric Strength:

Between non-intrinsically safe part and intrinsically safe part ≥2500V AC

Between power supply part and output part ≥500V AC

Insulation Resistance:

Between non-intrinsically safe part and intrinsically safe part ≥100MΩ

Between power supply part and output part ≥100MΩ

Structure: GS8500 range structure customized by Phoenix Contact

Weight: Approx.150g

Suitable Location: Mounting in safe area, and connected to the IS apparatus in hazardous area up to zone0 IIC and zone20 IIIC.

Suitable Field Apparatus: With RS-232 communication interface device



Dimensions: 118.9mm×106.0mm×17.5mm

Connection

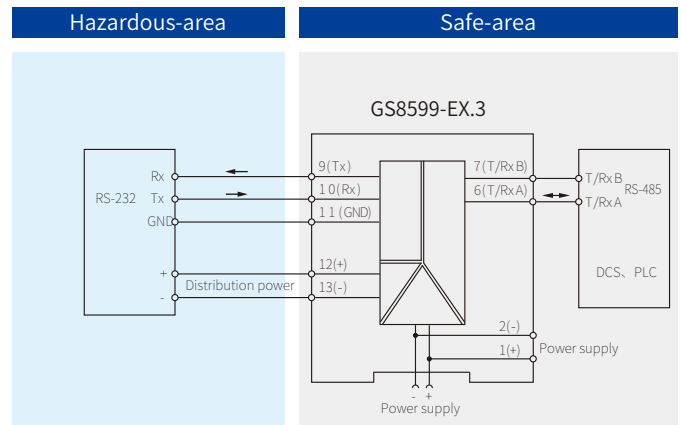

Note: Bus-powered function is optional, if necessary please specified when ordering, and purchase bus power accessories in additional.

Explosion-proof Certificate

Certifying Authority: NEPSI(China)

Ex Marking: [Ex ia Ga] II C

[Ex iaD]

Maximum Voltage: Um=250V

Intrinsic Safety Parameters(9、 11; 10、 11 terminals):

$U_o=11.7V$, $I_o=4.0mA$, $P_o=12mW$

(9、 10、 11 terminals):

$U_o=23.5V$, $I_o=8.5mA$, $P_o=50mW$

II C: $C_o=0.12\mu F$, $L_o=100mH$

*II B: $C_o=0.97\mu F$, $L_o=300mH$

II A: $C_o=3.52\mu F$, $L_o=800mH$

(12、 13 terminals):

$U_o=23.1V$, $I_o=187mA$, $P_o=1.08W$

II C: $C_o=0.1\mu F$, $L_o=0.8mH$

*II B: $C_o=1.0\mu F$, $L_o=2.4mH$

II A: $C_o=3.6\mu F$, $L_o=6.4mH$

*II B Intrinsic Safety Parameters are also suitable for dust explosion protection[Ex iaD]